

Installation:

1st nut should be spanned with 40 - 45Nm.
 2nd nut should shall be brought at least to a snug-tight condition, with special care being given to avoid over-tightening.
 Nut-marking should be made acc. to figure after torque.

M16 nut:

1st and 2nd nut should shall be brought at least to a snug-tight condition, with special care being given to avoid over-tightening.
 Nut-marking should be made acc. to figure after torque.

Maintenance:

Visual inspection of bolt torque and any loose items is made 1 year after installation, and afterwards every 5th year.
 Check if the marking from bolt torque is still straight.
 Check if the corrosion protection system is satisfactory.
 Any findings must be repaired as soon as possible.

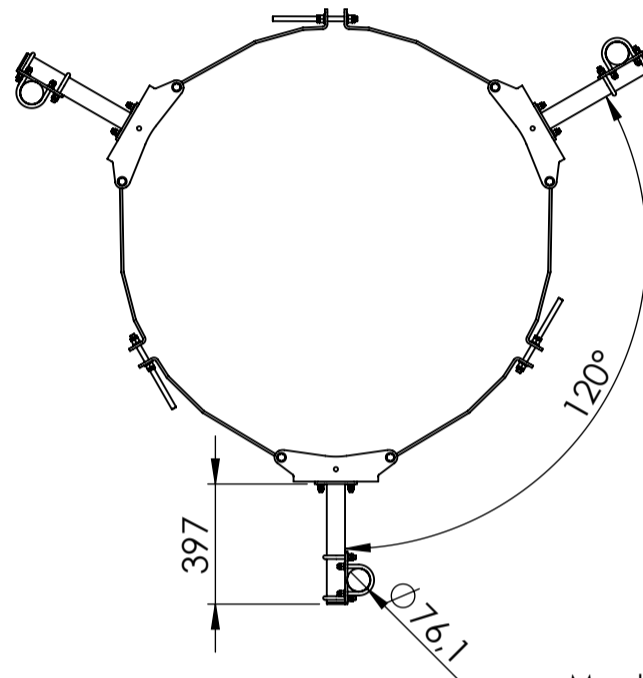
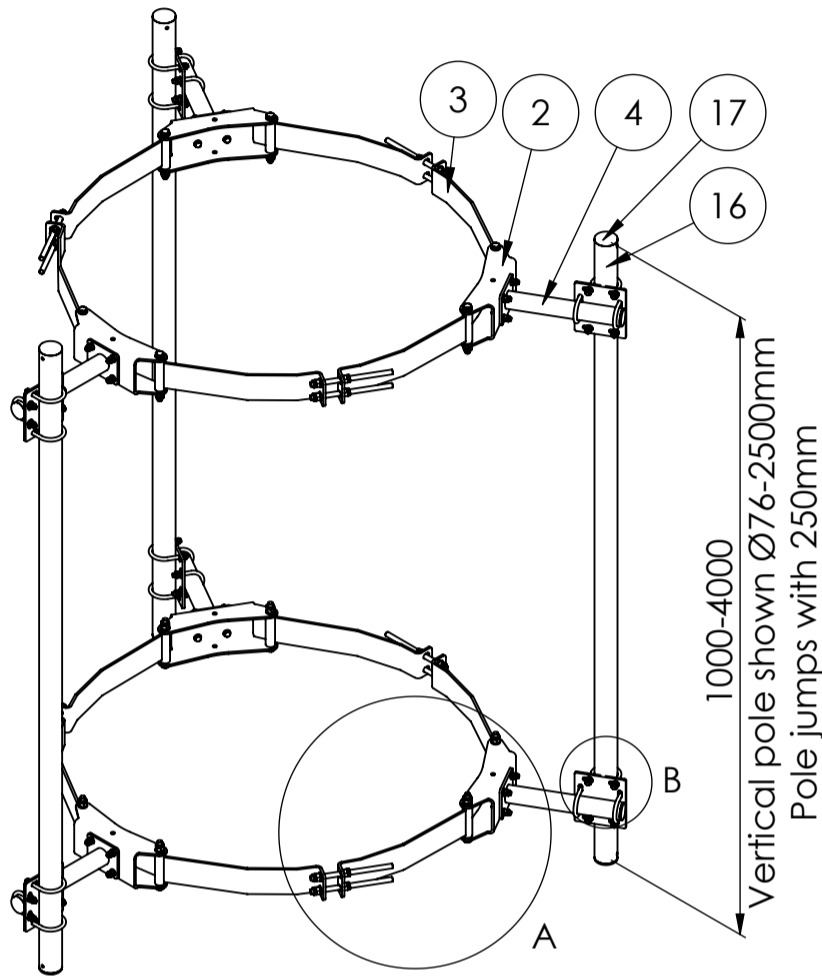
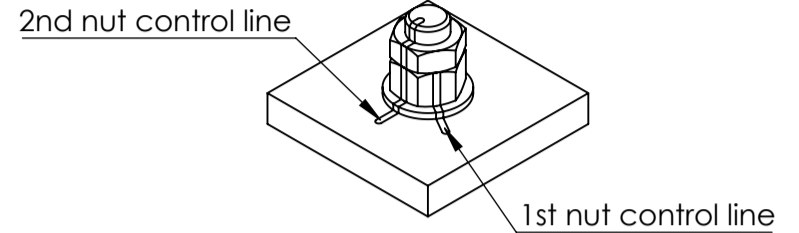

Basic wind $V_{b,0} = 27 \text{ m/s}$
 Terrain class $TC = 1$
 Max height of installation = 70m

Max loads per 1 mount pole from equipment: 150kg, $C_{xA} = 1.6\text{m}^2$

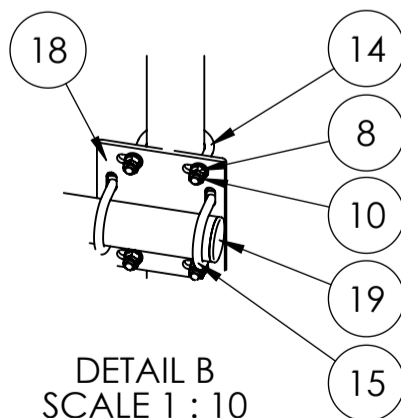
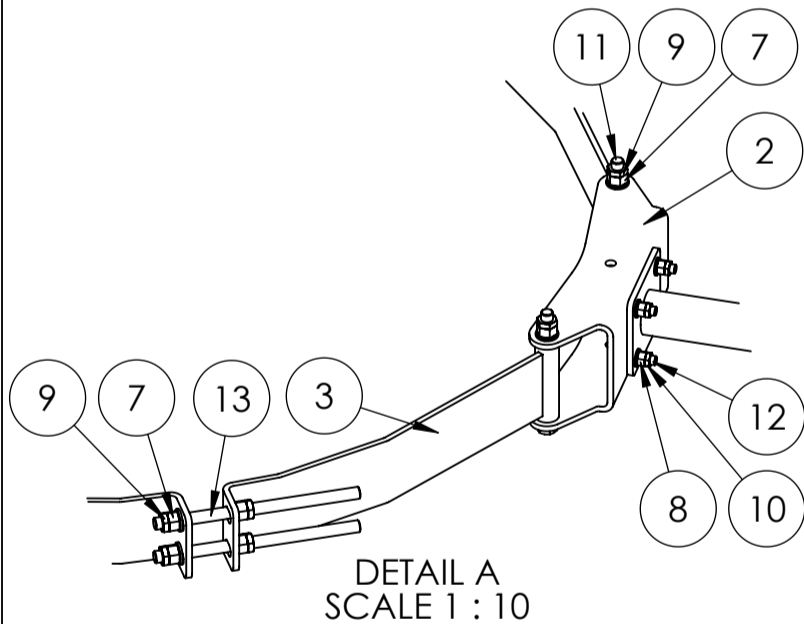

ITEM NO.	PART NUMBER	DESCRIPTION	QTY.
2	VB-Ø1000-3000 300	Horizontal pole bracket Ø1000-3000	6
3	VBA-Ø1410-1520	Horizontal bracket for Ø1410-1520	12
4	CVBM_H400	Horizontal pole for C and V bracket	6
5	Washer ISO 7089 - 16		48
6	Washer ISO 7089 - 12		96
7	ISO - 4032 - M16 - W - N		36
8	ISO - 4032 - M12 - W - N		72
9	ISO - 4035 - M16 - N		36
10	ISO - 4035 - M12 - N		72
11	ISO 4014 - M16 x 180		12
12	ISO 4017 - M12 x 45-N		24
13	M16x280 DIN976	Horizontal pole bracket pin-bolts	12
14	U-bolt M12 C-C = 90		12
15	U-bolt M12 C-C = 75		12
16	Pole Ø76-2500	Vertical pole Ø76,1 - length: 2500	3
17	GL 76x1.6-4	tubular legs for Ø76,1	6
18	MB-Ø60-76 300	Bracket vertical pole Ø60,3-76.1	6
19	GL 60x3-5	tubular legs for Ø60,3	6

Rev.:	Int.:	Date:	Comment		
Customer.:					
Subjekt.:		Antenna offset f. Ø1410-1520 with multi adjustable brackets			
Date.:	15-07-2020	Production no.:	Scale.:	1:25	Format:A3
Order no.:		Calculation:	Int.:	SP/MRF	Projektion:
Drawing. No.:	VBM-Ø1410-1520 H400	Note.:			
Tolerance: DS/EN 1090-2 DS/ISO 2768-2-L					